

Features

- Diffused Junction
- Low Forward Voltage Drop
- High Current Capability
- High Reliability
- High Surge Current Capability

Mechanical Data

- Case: P-600, Molded Plastic
- Terminals: Plated Leads Solderable per MIL-STD-202, Method 208
- Polarity: Cathode Band
- Weight: 2.1 grams (approx.)
- Mounting Position: Any
- Marking: Type Number
- **Lead Free: For RoHS / Lead Free Version**

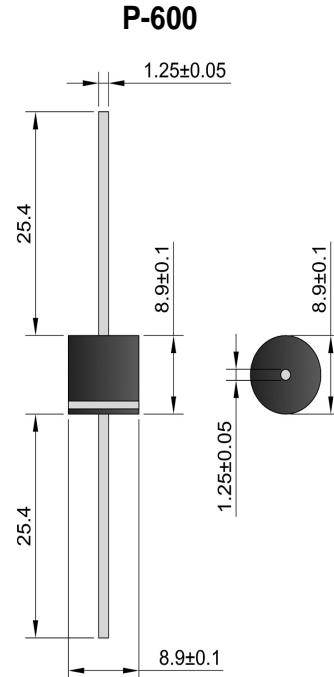

Maximum Ratings and Electrical Characteristics @ $T_A=25^\circ\text{C}$ unless otherwise specified

Single Phase, half wave, 60Hz, resistive or inductive load.
For capacitive load, derate current by 20%.

Characteristic	Symbol	10A05	10A1	10A2	10A4	10A6	10A8	10A10	Unit	
Peak Repetitive Reverse Voltage	V_{RRM}									
Working Peak Reverse Voltage	V_{RWM}	50	100	200	400	600	800	1000	V	
DC Blocking Voltage	V_R									
RMS Reverse Voltage	$V_{R(RMS)}$	35	70	140	280	420	560	700	V	
Average Rectified Output Current (Note 1) @ $T_A = 50^\circ\text{C}$	I_O	10								A
Non-Repetitive Peak Forward Surge Current 8.3ms Single Half Sine-Wave Superimposed on Rated Load (JEDEC Method)	I_{FSM}	600								A
Forward Voltage @ $I_F = 10\text{A}$	V_{FM}	1.0								V
Peak Reverse Current @ $T_A = 25^\circ\text{C}$ At Rated DC Blocking Voltage @ $T_A = 100^\circ\text{C}$	I_{RM}	10 100								μA
Typical Junction Capacitance (Note 2)	C_J	150				80			pF	
Typical Thermal Resistance Junction to Ambient (Note 3)	R_{JA}	15								$^\circ\text{C}/\text{W}$
Operating and Storage Temperature Range	T_J, T_{STG}	-50 to +150								$^\circ\text{C}$

- Note: 1. Leads maintained at ambient temperature at a distance of 9.5mm from the case.
2. Measured at 1.0 MHz and Applied Reverse Voltage of 4.0V D.C.
3. Mounted on FR-4 PCB with 30mm x 30mm copper pad.

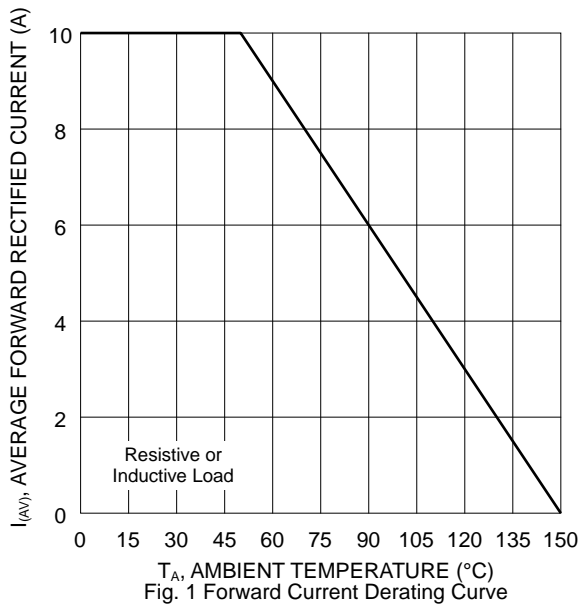

Fig. 1 Forward Current Derating Curve

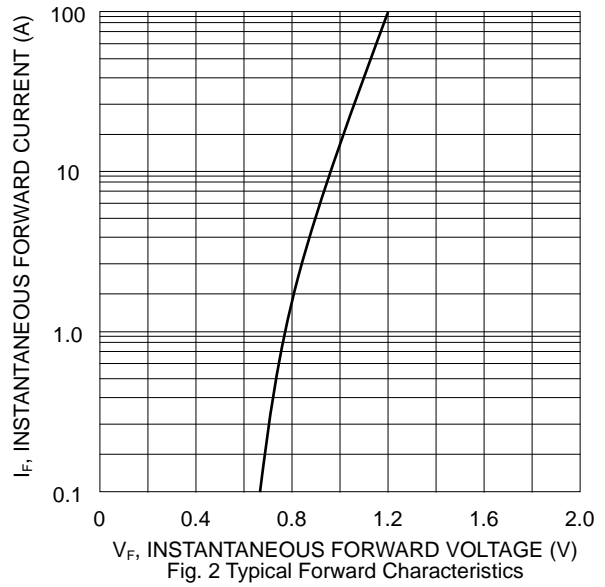

Fig. 2 Typical Forward Characteristics

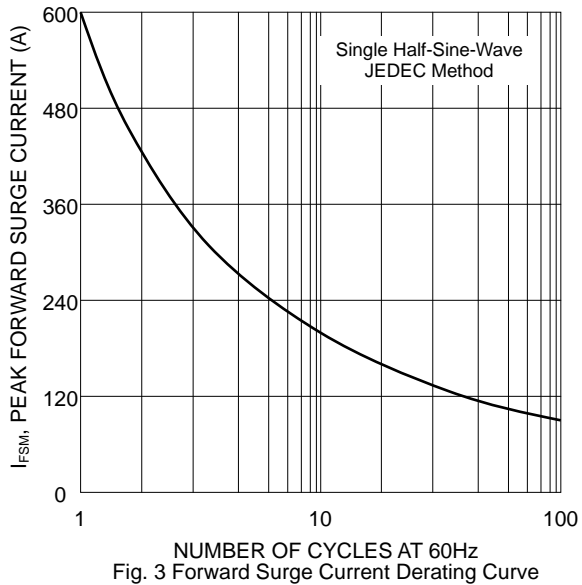

Fig. 3 Forward Surge Current Derating Curve

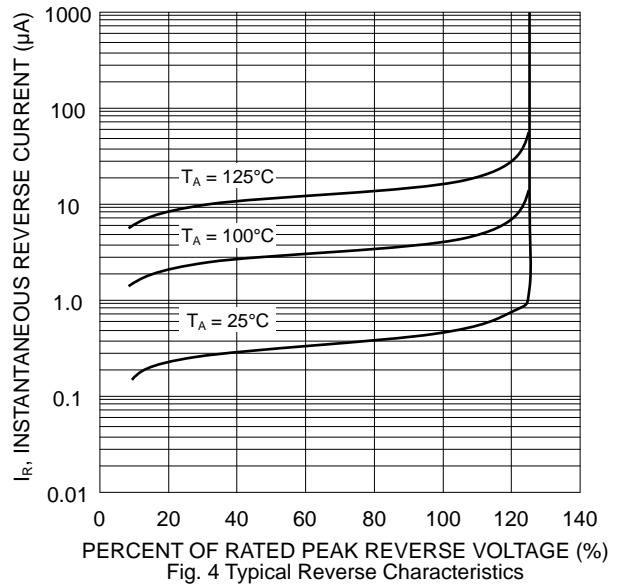

Fig. 4 Typical Reverse Characteristics

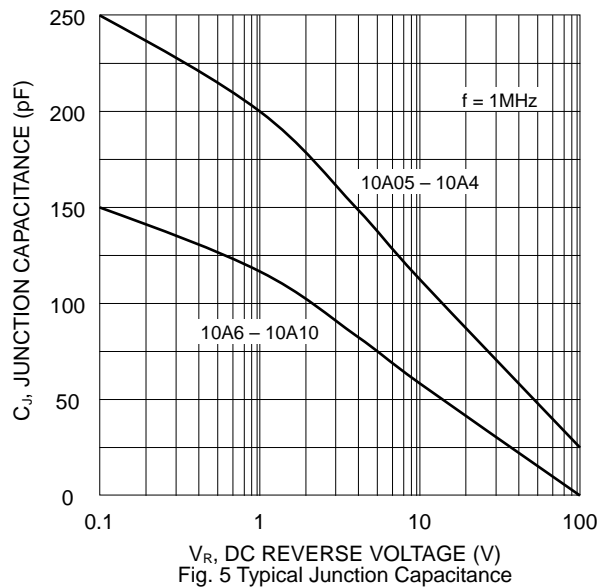
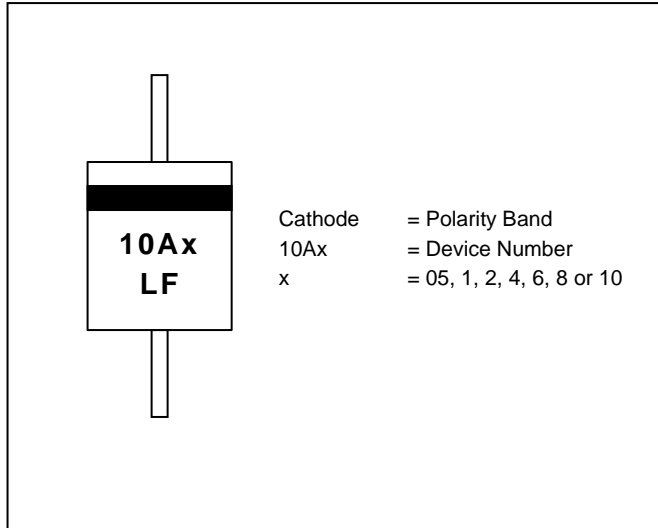
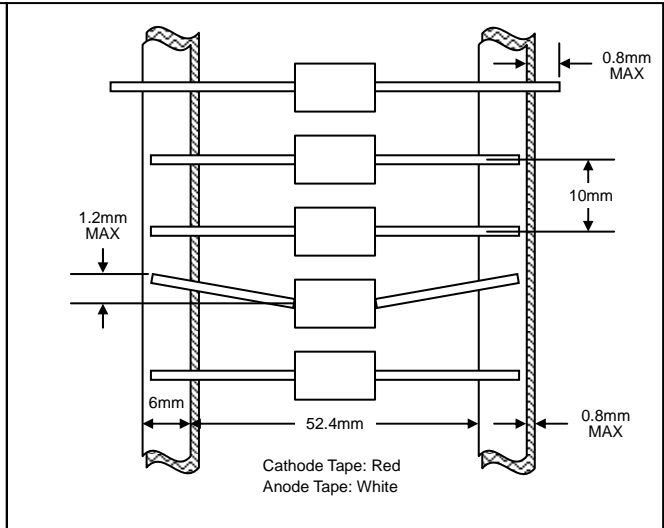

Fig. 5 Typical Junction Capacitance

MARKING INFORMATION



TAPING SPECIFICATIONS



PACKAGING INFORMATION

TAPE & REEL

330mm
 Product ID Label
 80±5mm

BULK

50mm
 210mm
 85mm

Packaging	Reel Diameter / Box Size (mm)	Quantity (PCS)	Carton Size (mm)	Quantity (PCS)	Approx. Gross Weight (KG)
TAPE & REEL	330	800	370 x 370 x 420	4,000	12.0
BULK	210 x 85 x 50	250	500 x 255 x 275	7,000	17.0