

### Features

- Diffused Junction
- Low Forward Voltage Drop
- High Surge Current Capability
- High Reliability
- Ideally Suited for Use in High Frequency SMPS, Inverters and As Free Wheeling Diodes

### Mechanical Data

- Case: DO-201AD, Molded Plastic
- Terminals: Plated Leads Solderable per MIL-STD-202, Method 208
- Polarity: Cathode Band
- Weight: 1.2 grams (approx.)
- Mounting Position: Any
- Marking: Type Number
- **Lead Free: For RoHS / Lead Free Version**

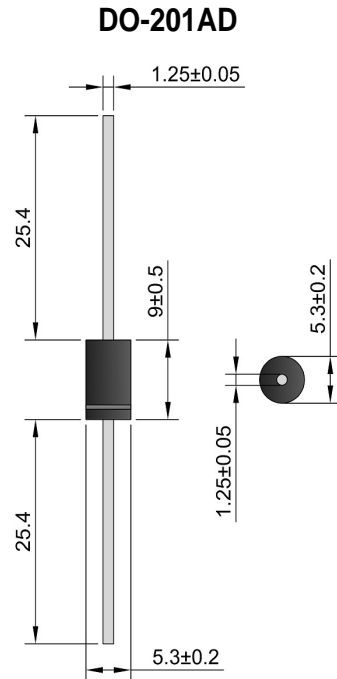

### Maximum Ratings and Electrical Characteristics @T<sub>A</sub>=25°C unless otherwise specified

Single Phase, half wave, 60Hz, resistive or inductive load.  
For capacitive load, derate current by 20%.

Characteristic	Symbol	UF 5400	UF 5401	UF 5402	UF 5403	UF 5404	UF 5406	UF 5407	UF 5408	Unit
Peak Repetitive Reverse Voltage	V <sub>RRM</sub>	50	100	200	300	400	600	800	1000	V
Working Peak Reverse Voltage	V <sub>RWM</sub>									
DC Blocking Voltage	V <sub>R</sub>									
RMS Reverse Voltage	V <sub>R(RMS)</sub>	35	70	140	210	280	420	560	700	V
Average Rectified Output Current (Note 1) @T <sub>A</sub> = 55°C	I <sub>O</sub>	3.0								A
Non-Repetitive Peak Forward Surge Current 8.3ms Single Half Sine-Wave Superimposed on Rated Load (JEDEC Method)	I <sub>FSM</sub>	150								A
Forward Voltage @I <sub>F</sub> = 3.0A	V <sub>FM</sub>	1.0			1.3		1.7			V
Peak Reverse Current @T <sub>A</sub> = 25°C At Rated DC Blocking Voltage @T <sub>A</sub> = 100°C	I <sub>RM</sub>	10 100								μA
Reverse Recovery Time (Note 2)	t <sub>rr</sub>	50				75				nS
Typical Junction Capacitance (Note 3)	C <sub>J</sub>	45				36				pF
Typical Thermal Resistance Junction to Ambient (Note 1)	R <sub>JA</sub>	20								°C/W
Typical Thermal Resistance Junction to Lead (Note 1)	R <sub>JL</sub>	8.5								
Operating Temperature Range	T <sub>J</sub>	-65 to +125								°C
Storage Temperature Range	T <sub>STG</sub>	-65 to +150								°C

Note: 1. Leads maintained at ambient temperature at a distance of 9.5mm from the case.  
2. Measured with I<sub>F</sub> = 0.5A, I<sub>R</sub> = 1.0A, I<sub>RR</sub> = 0.25A.  
3. Measured at 1.0 MHz and Applied Reverse Voltage of 4.0V D.C.

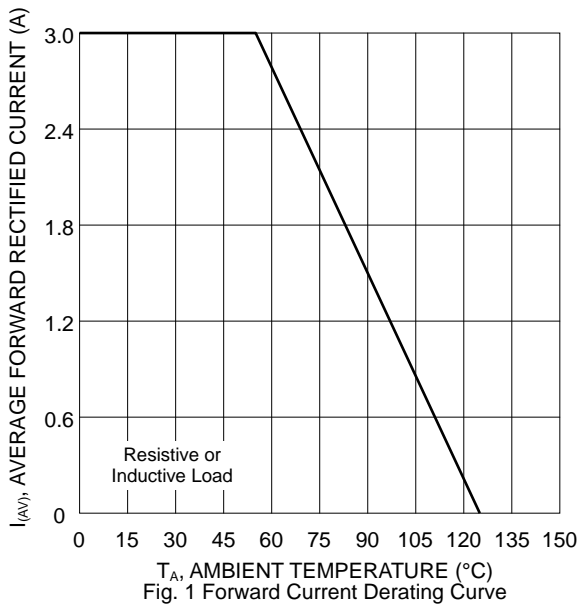

Fig. 1 Forward Current Derating Curve

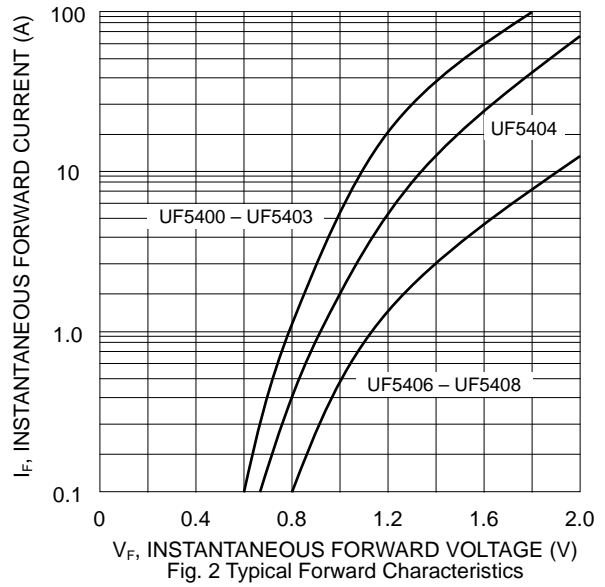

Fig. 2 Typical Forward Characteristics

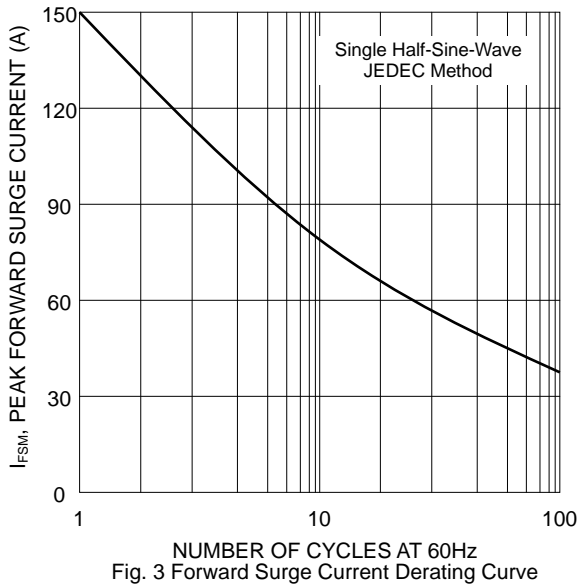

Fig. 3 Forward Surge Current Derating Curve

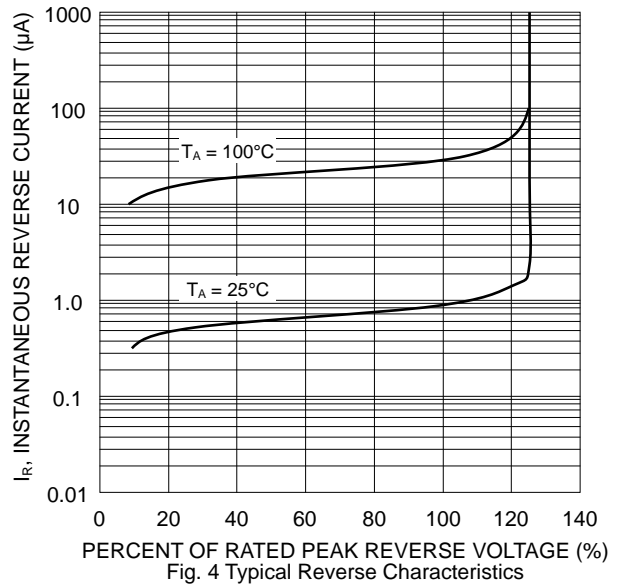

Fig. 4 Typical Reverse Characteristics

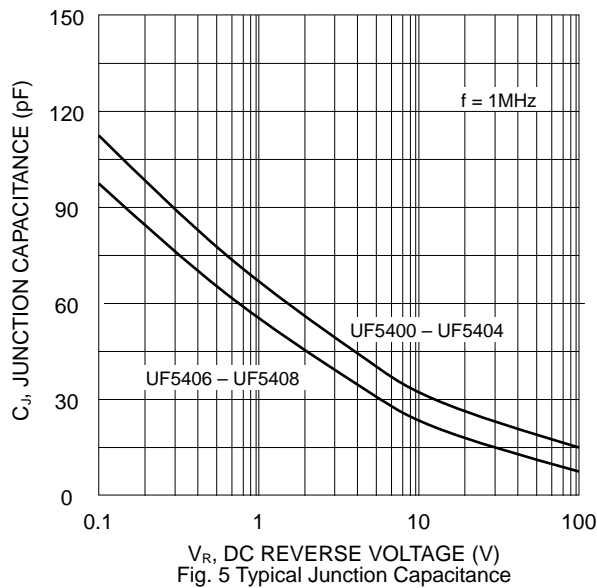
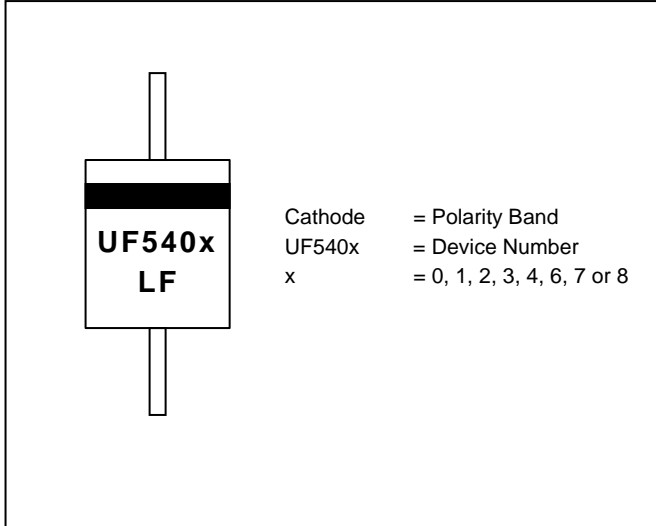
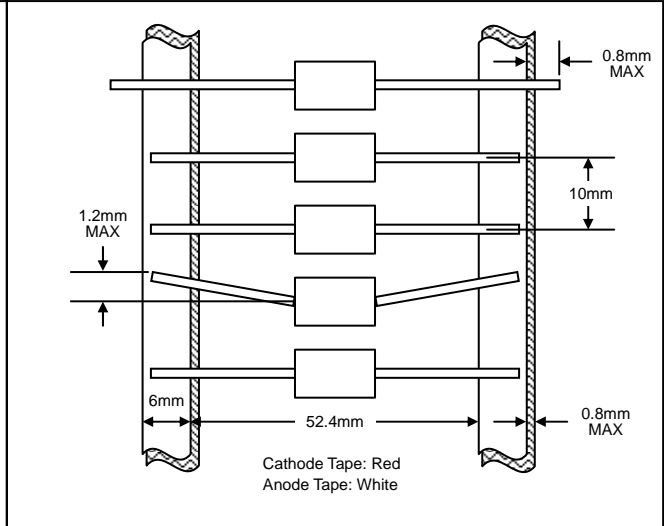

Fig. 5 Typical Junction Capacitance

## MARKING INFORMATION



## TAPING SPECIFICATIONS



## PACKAGING INFORMATION

### TAPE & REEL

330mm  
 Product ID Label  
 80±5mm

### TAPE & BOX

150mm  
 Product ID Label  
 Inspection Hole (both ends)  
 255mm  
 75mm

### BULK

40mm  
 200mm  
 85mm

Packaging	Reel Diameter / Box Size (mm)	Quantity (PCS)	Carton Size (mm)	Quantity (PCS)	Approx. Gross Weight (KG)
<b>TAPE &amp; REEL</b>	330	5,000	370 x 370 x 420	25,000	13.0
<b>TAPE &amp; BOX</b>	255 x 75 x 150	5,000	400 x 273 x 415	50,000	21.0
<b>BULK</b>	198 x 84 x 20	1,000	459 x 214 x 256	50,000	19.5