

### Features

- Fred Chip Planar Construction
- Ultrafast 50nS and 100nS Recovery Time
- Low Forward Voltage Drop
- Low Reverse Leakage Current
- High Surge Current Capability
- Epoxy Meets UL 94V-0 Classification
- Ideally Suited for Use in High Frequency SMPS, Inverters and As Free Wheeling Diodes

### Mechanical Data

- Case: ITO-220A, Full Molded Plastic
- Terminals: Plated Leads Solderable per MIL-STD-202, Method 208
- Polarity: See Diagram
- Weight: 1.9 grams (approx.)
- Mounting Position: Any
- Mounting Torque: 0.6 N.m Max.
- **Lead Free: For RoHS / Lead Free Version**

### TO-220AC

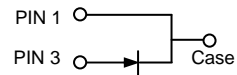
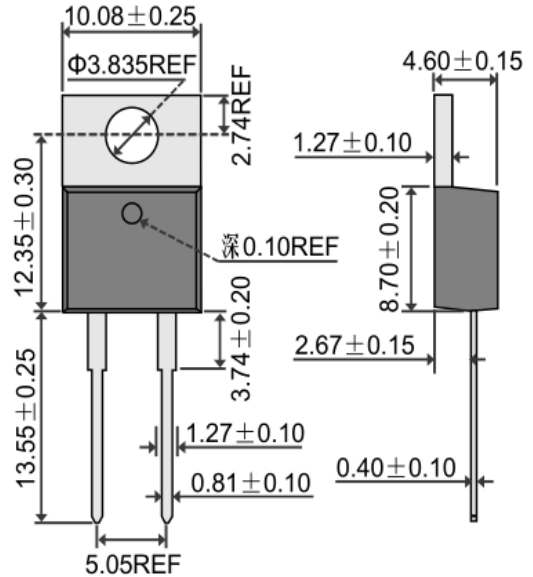

### Maximum Ratings and Electrical Characteristics @<sub>T<sub>A</sub></sub>=25°C unless otherwise specified

Single Phase, half wave, 60Hz, resistive or inductive load. For capacitive load, derate current by 20%.

Characteristic	Symbol	UF 1000F	UF 1001F	UF 1002F	UF 1003F	UF 1004F	UF 1006F	UF 1008F	Unit
Peak Repetitive Reverse Voltage	V <sub>RRM</sub>								V
Working Peak Reverse Voltage	V <sub>RWM</sub>	50	100	200	300	400	600	800	
DC Blocking Voltage	V <sub>R</sub>								
RMS Reverse Voltage	V <sub>R(RMS)</sub>	35	70	140	210	280	420	560	V
Average Rectified Output Current @ <sub>T<sub>C</sub></sub> = 100°C	I <sub>O</sub>	10							A
Non-Repetitive Peak Forward Surge Current 8.3ms Single Half Sine-Wave Superimposed on Rated Load (JEDEC Method)	I <sub>FSM</sub>	150							A
Forward Voltage @ <sub>I<sub>F</sub></sub> = 10A	V <sub>FM</sub>	1.0			1.3		1.7		V
Peak Reverse Current @ <sub>T<sub>A</sub></sub> = 25°C At Rated DC Blocking Voltage @ <sub>T<sub>A</sub></sub> = 125°C	I <sub>RM</sub>	10 500							μA
Reverse Recovery Time (Note 1)	t <sub>rr</sub>	50					100		nS
Typical Junction Capacitance (Note 2)	C <sub>J</sub>	80					50		pF
Thermal Resistance Junction to Ambient	R <sub>JA</sub>	75							°C/W
Thermal Resistance Junction to Case	R <sub>JC</sub>	5.0							
RMS Isolation Voltage, t = 1 min	V <sub>ISO</sub>	1500							V
Operating and Storage Temperature Range	T <sub>J</sub> , T <sub>STG</sub>	-55 to +150							°C

Note: 1. Measured with I<sub>F</sub> = 0.5A, I<sub>R</sub> = 1.0A, I<sub>RR</sub> = 0.25A.  
2. Measured at 1.0 MHz and applied reverse voltage of 4.0V D.C.

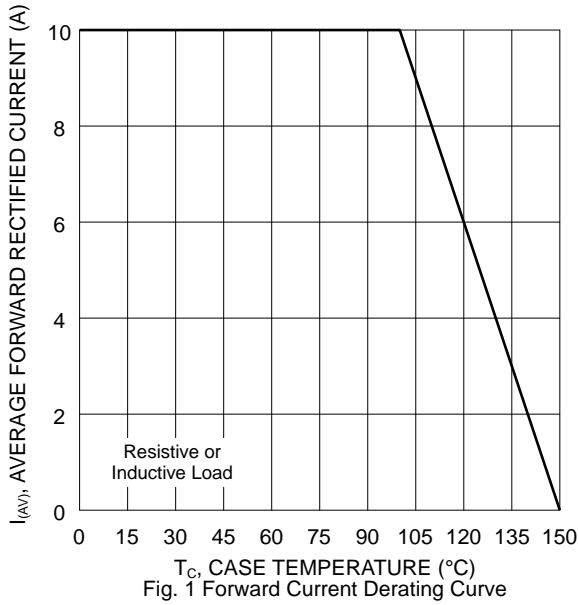

Fig. 1 Forward Current Derating Curve

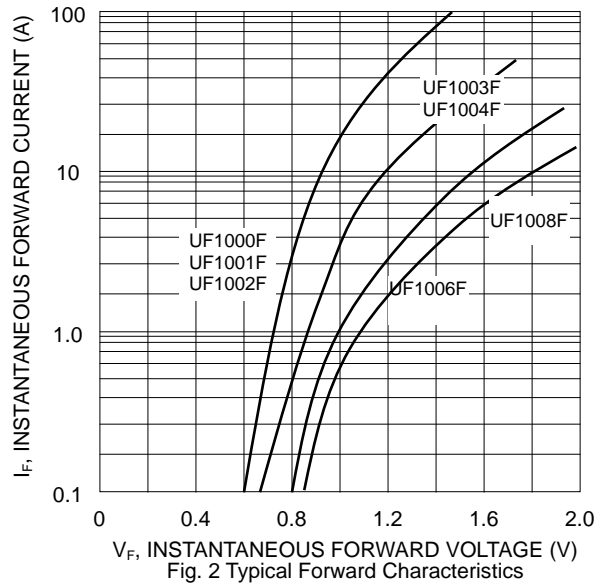

Fig. 2 Typical Forward Characteristics

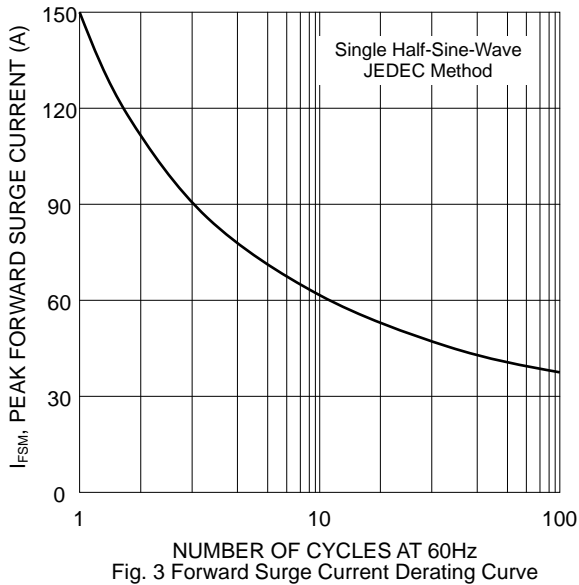

Fig. 3 Forward Surge Current Derating Curve

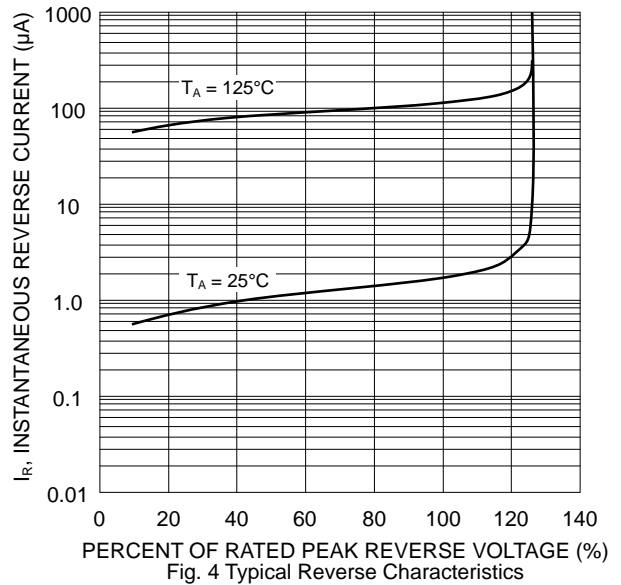

Fig. 4 Typical Reverse Characteristics

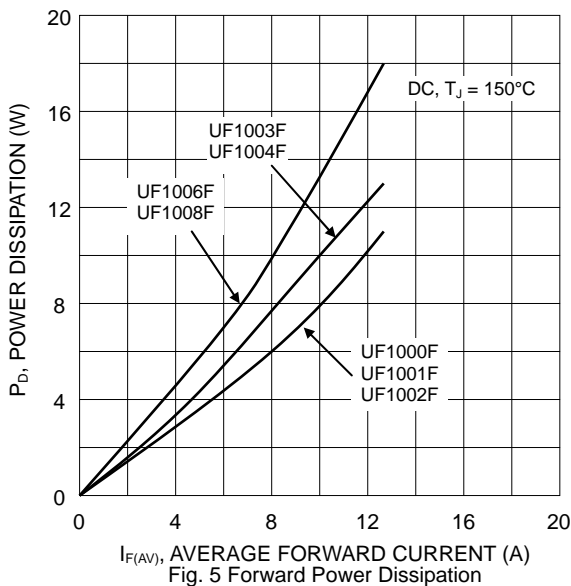

Fig. 5 Forward Power Dissipation

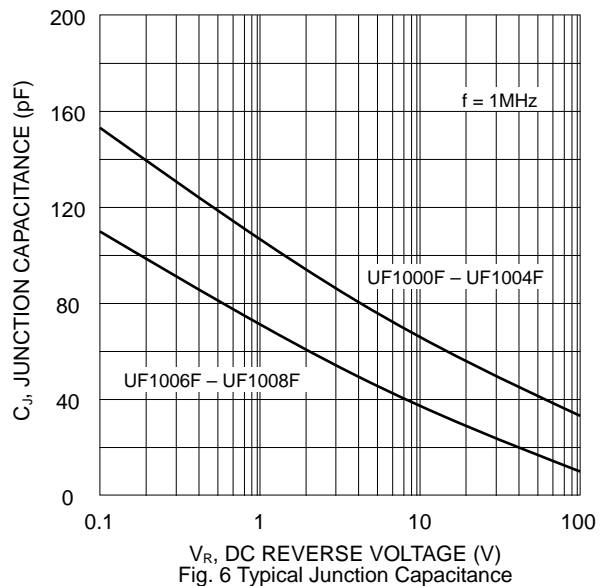
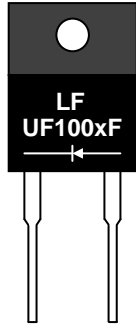

Fig. 6 Typical Junction Capacitance

## MARKING INFORMATION



UF100xF = Device Number  
 x = 0, 1, 2, 3, 4, 6 or 8  
 Polarity = As Marked on Body

## PACKAGING INFORMATION

**BULK**

Tube Size L x W x H (mm)	Quantity (PCS)	Inner Box Size L x W x H (mm)	Quantity (PCS)	Carton Size L x W x H (mm)	Quantity (PCS)	Approx. Gross Weight (KG)
525 x 31 x 6	50	558 x 150 x 40	1,000	570 x 235 x 170	5,000	11.85

## RECOMMENDED SCREW MOUNTING ARRANGEMENT

The full molded plastic package affords a major reduction of hardware as compared to a standard TO-220 package. However, precautions should be made in mounting procedure.

A conical washer should be used to apply proper force to the device. Screw should not be tightened with any type of air-forced torque or equipment that may cause crack on device package.

A layer of thermal grease or thermal pad in the interface will be considerably helpful for heat dissipation.

