

MURB1020CT – MURB1060CT

10A SURFACE MOUNT GLASS PASSIVATED DUAL SUPERFAST RECTIFIER

Features

-
- Ideally Suited for Automatic Assembly
- Super-Fast Recovery Time
- High Voltage Capability
- Low Power Loss, High Efficiency
- High Surge Current Capability
- For Use in High Voltage, High Frequency Inverters, Free Wheeling, and Switching Power Supplies

Mechanical Data

- Case: D²PAK/TO-263, Molded Plastic
- Terminals: Plated Leads Solderable per MIL-STD-202, Method 208
- Polarity: See Diagram
- Weight: 1.7 grams (approx.)
- Mounting Position: Any
- Marking: Device Code, See Page 3
- **Lead Free: For RoHS / Lead Free Version**

D²PAK/TO-263

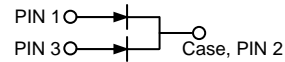
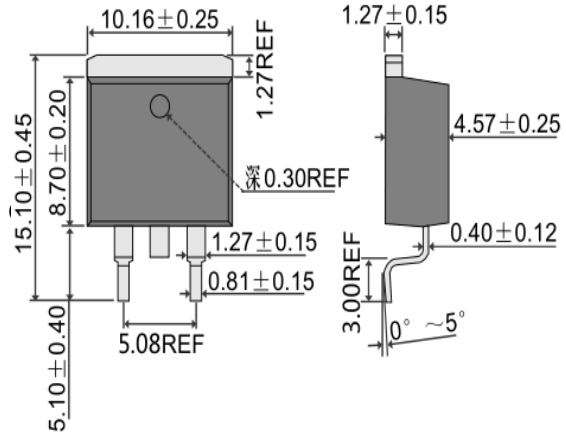

Maximum Ratings and Electrical Characteristics @T_A=25°C unless otherwise specified

Single Phase, half wave, 60Hz, resistive or inductive load. For capacitive load, derate current by 20%.

Characteristic	Symbol	MURB 1020CT	MURB 1030CT	MURB 1040CT	MURB 1060CT	Unit
Peak Repetitive Reverse Voltage	V _{RRM}					
Working Peak Reverse Voltage	V _{RWM}	200	300	400	600	V
DC Blocking Voltage	V _R					
RMS Reverse Voltage	V _{R(RMS)}	140	210	280	420	V
Average Rectified Output Current @T _C = 100°C	Total Device Per Diode I _O		10 5.0			A
Non-Repetitive Peak Forward Surge Current 8.3ms Single Half Sine-Wave Superimposed on Rated Load (JEDEC Method)	I _{FSM}		150			A
Forward Voltage per diode @I _F = 5.0A	V _{FM}	0.95	1.3	1.7		V
Peak Reverse Current At Rated DC Blocking Voltage	I _{RM}		10 500			μA
Reverse Recovery Time (Note 1)	t _{rr}	35		50		nS
Typical Junction Capacitance (Note 2)	C _J	70		50		pF
Thermal Resistance Junction to Ambient per diode	R _{JA}		60			°C/W
Thermal Resistance Junction to Case per diode	R _{JC}		3.0			
Operating and Storage Temperature Range	T _J , T _{STG}		-55 to +150			°C

Note: 1. Measured with I_F = 0.5A, I_R = 1.0A, I_{RR} = 0.25A.
2. Measured at 1.0 MHz and applied reverse voltage of 4.0V D.C.



MURB1020CT – MURB1060CT

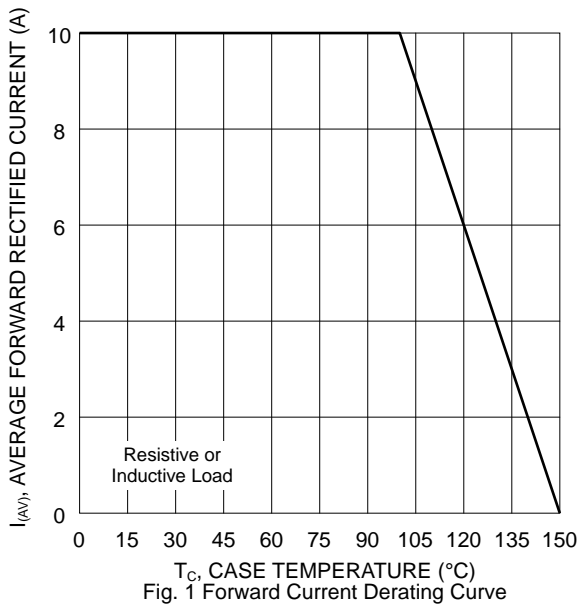

Fig. 1 Forward Current Derating Curve

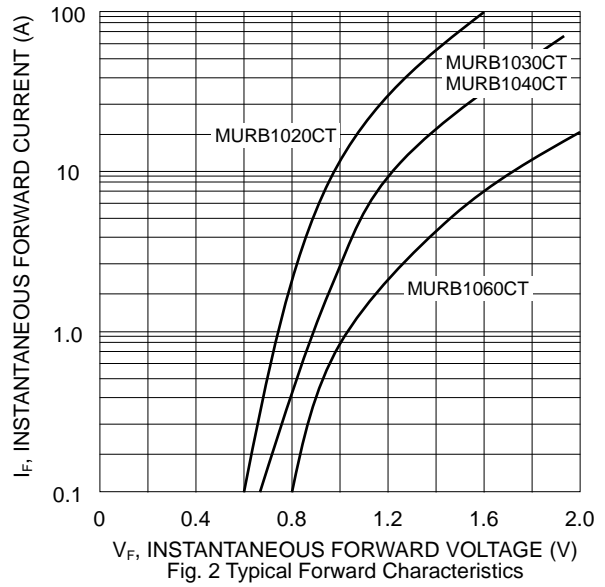

Fig. 2 Typical Forward Characteristics

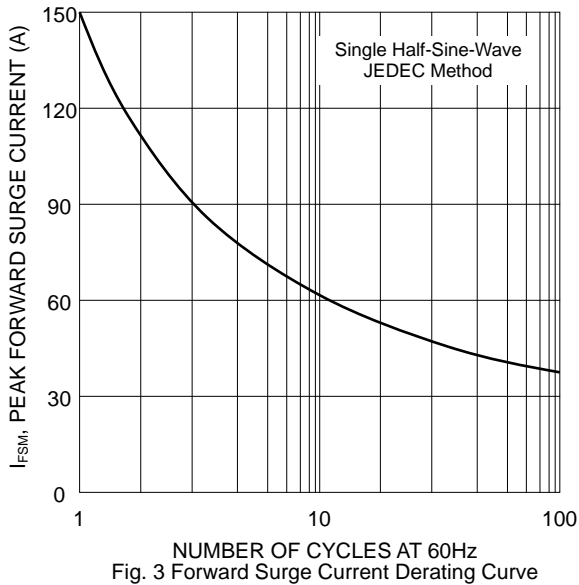

Fig. 3 Forward Surge Current Derating Curve

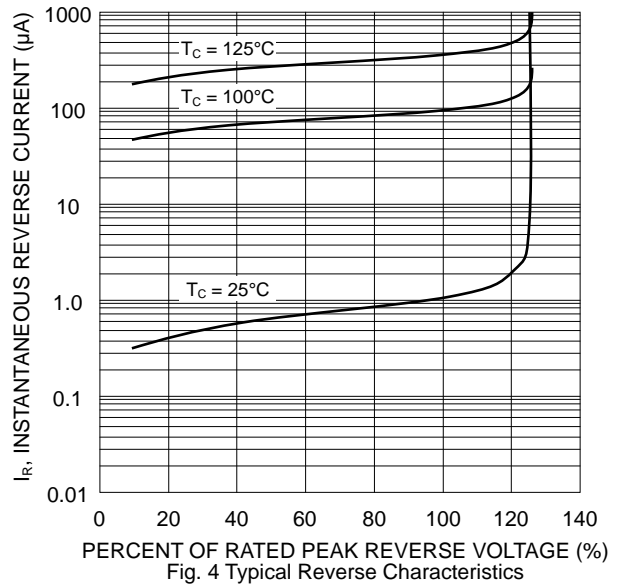

Fig. 4 Typical Reverse Characteristics

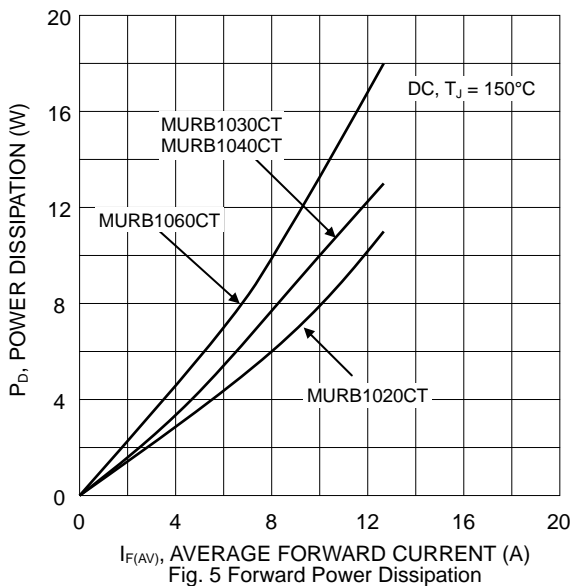

Fig. 5 Forward Power Dissipation

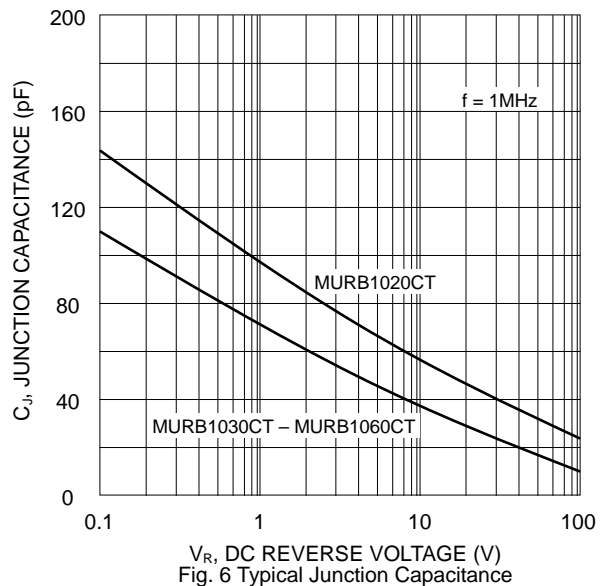
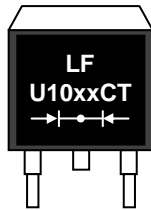

Fig. 6 Typical Junction Capacitance

MARKING INFORMATION



U10xxCT = Device Number
 xx = 20 (MURB1020CT)
 30 (MURB1030CT)
 40 (MURB1040CT)
 60 (MURB1060CT)
 Polarity = As Marked on Body

RECOMMENDED FOOTPRINT

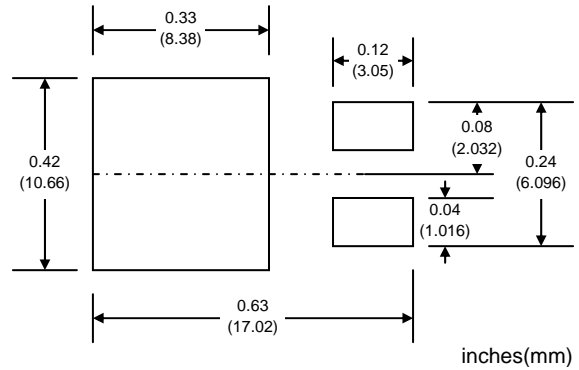

inches(mm)

PACKAGING INFORMATION

TAPE & REEL

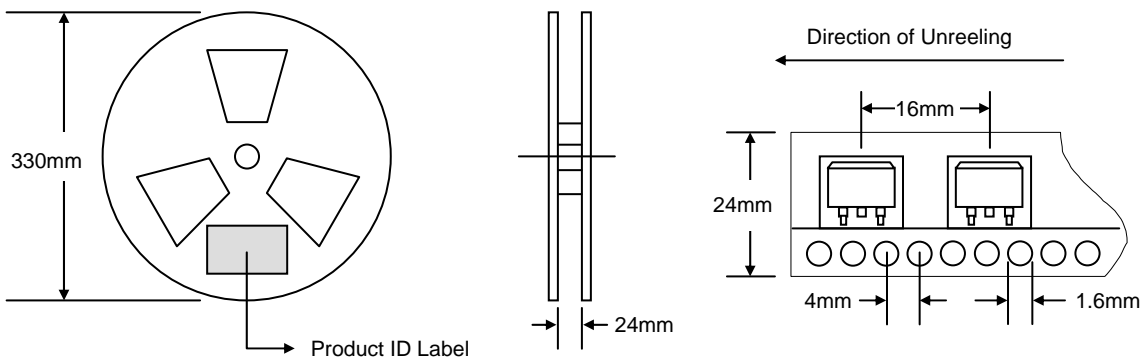

Reel Diameter (mm)	Quantity (PCS)	Inner Box Size L x W x H (mm)	Quantity (PCS)	Carton Size L x W x H (mm)	Quantity (PCS)	Approx. Gross Weight (KG)
330	800	340 x 337 x 45	800	370 x 370 x 420	6,400	15.0