

Features

- Fred Chip Planar Construction
- Ideally Suited for Automatic Assembly
- Super-Fast Recovery Time
- High Voltage Capability
- Low Power Loss, High Efficiency
- High Surge Current Capability
- For Use in High Voltage, High Frequency Inverters, Free Wheeling, and Switching Power Supplies

Mechanical Data

- Case: D²PAK/TO-263, Molded Plastic
- Terminals: Plated Leads Solderable per MIL-STD-202, Method 208
- Polarity: See Diagram
- Weight: 1.7 grams (approx.)
- Mounting Position: Any
- Marking: Device Code, See Page 3
- **Lead Free: For RoHS / Lead Free Version**

D²PAK/TO-263

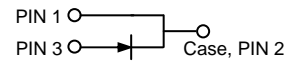
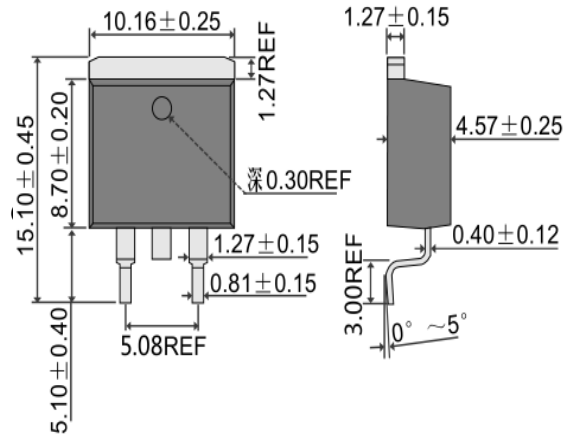

Maximum Ratings and Electrical Characteristics @T_A=25°C unless otherwise specified

Single Phase, half wave, 60Hz, resistive or inductive load. For capacitive load, derate current by 20%.

Characteristic	Symbol	MURB1620	MURB1630	MURB1640	MURB1660	Unit
Peak Repetitive Reverse Voltage	V _{RRM}					V
Working Peak Reverse Voltage	V _{RWM}	200	300	400	600	
DC Blocking Voltage	V _R					
RMS Reverse Voltage	V _{R(RMS)}	140	210	280	420	V
Average Rectified Output Current @T _C = 100°C	I _O	16				A
Non-Repetitive Peak Forward Surge Current 8.3ms Single Half Sine-Wave Superimposed on Rated Load (JEDEC Method)	I _{FSM}	250				A
Forward Voltage @I _F = 16A	V _{FM}	0.975	1.3	1.5		V
Peak Reverse Current @T _C = 25°C At Rated DC Blocking Voltage @T _C = 100°C	I _{RM}	10 500				μA
Reverse Recovery Time (Note 1)	t _{rr}	35	50			nS
Typical Junction Capacitance (Note 2)	C _J	175			145	pF
Thermal Resistance Junction to Ambient	R _{JA}	73				°C/W
Thermal Resistance Junction to Case	R _{JC}	1.2				
Operating and Storage Temperature Range	T _J , T _{STG}	-65 to +175				°C

Note: 1. Measured with I_F = 0.5A, I_R = 1.0A, I_{RR} = 0.25A.
2. Measured at 1.0 MHz and applied reverse voltage of 4.0V D.C.



MURB1620 – MURB1660

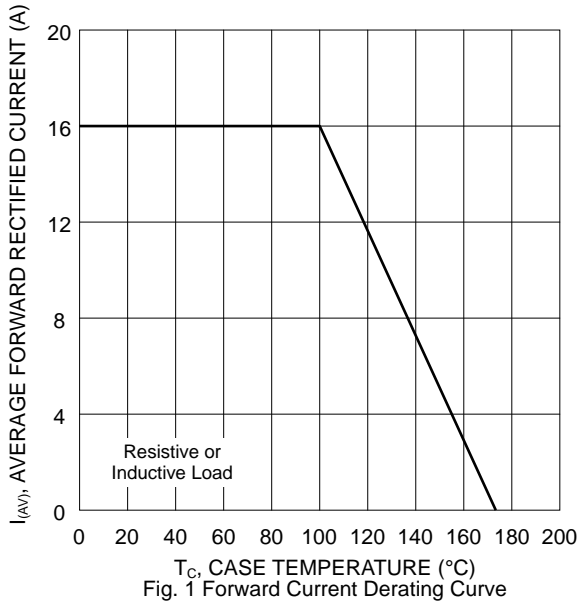

Fig. 1 Forward Current Derating Curve

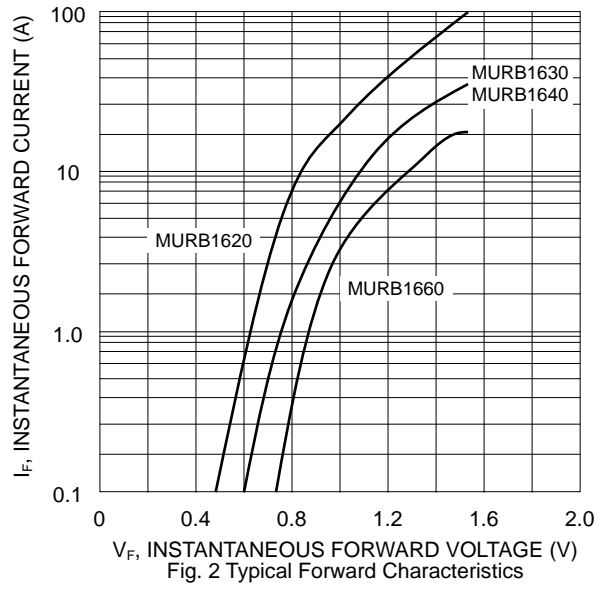

Fig. 2 Typical Forward Characteristics

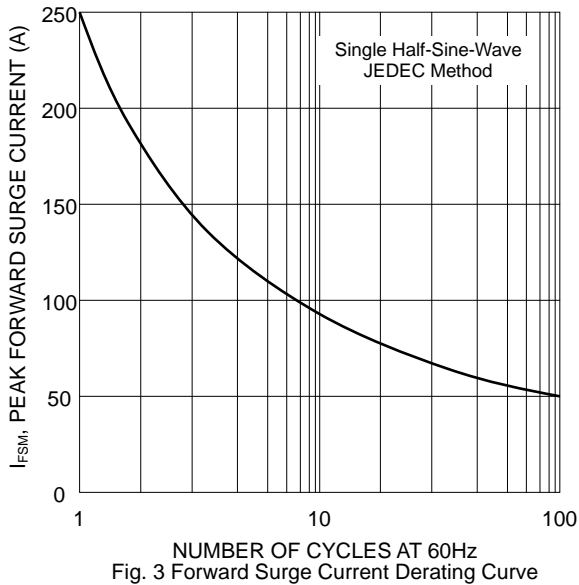

Fig. 3 Forward Surge Current Derating Curve

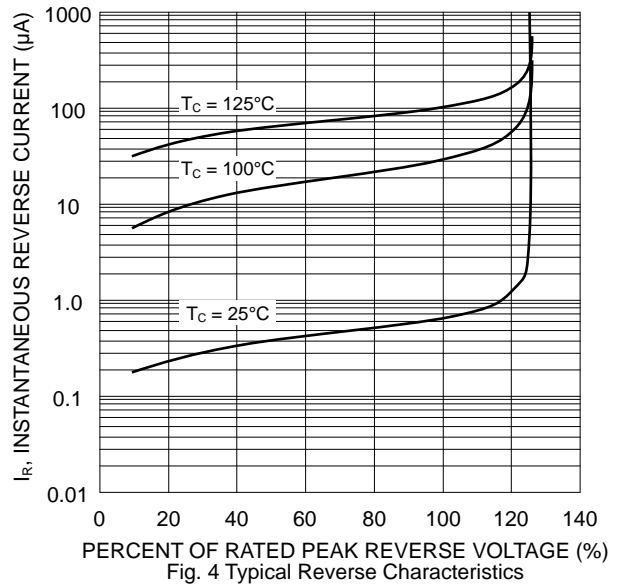

Fig. 4 Typical Reverse Characteristics

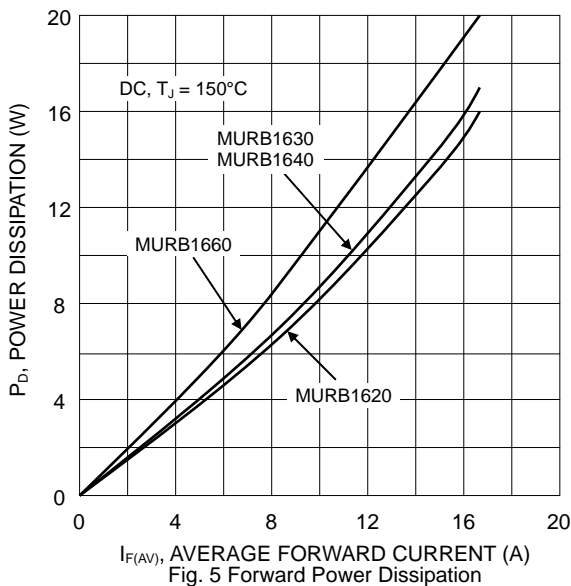

Fig. 5 Forward Power Dissipation

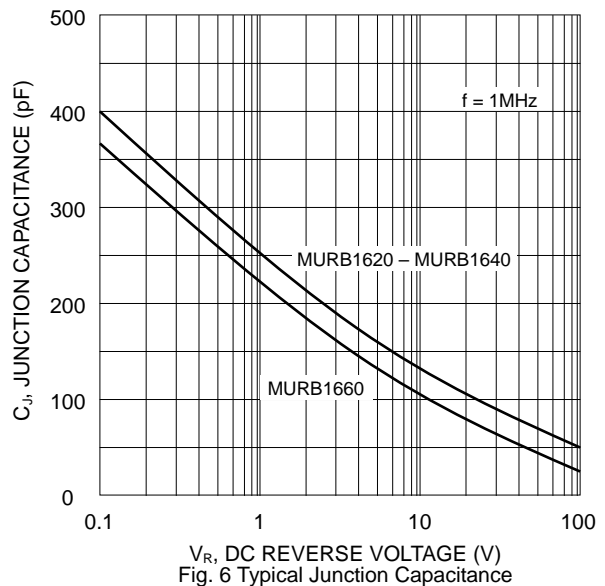
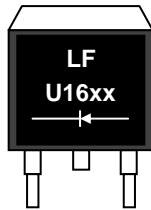

Fig. 6 Typical Junction Capacitance

MARKING INFORMATION



U16xx = Device Number
 xx = 20 (MURB1620)
 30 (MURB1630)
 40 (MURB1640)
 60 (MURB1660)
 Polarity = As Marked on Body

RECOMMENDED FOOTPRINT

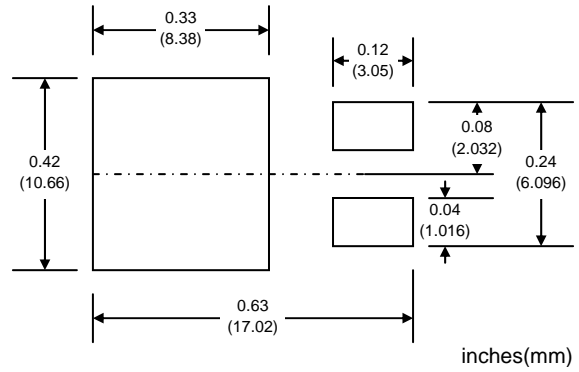

PACKAGING INFORMATION

TAPE & REEL

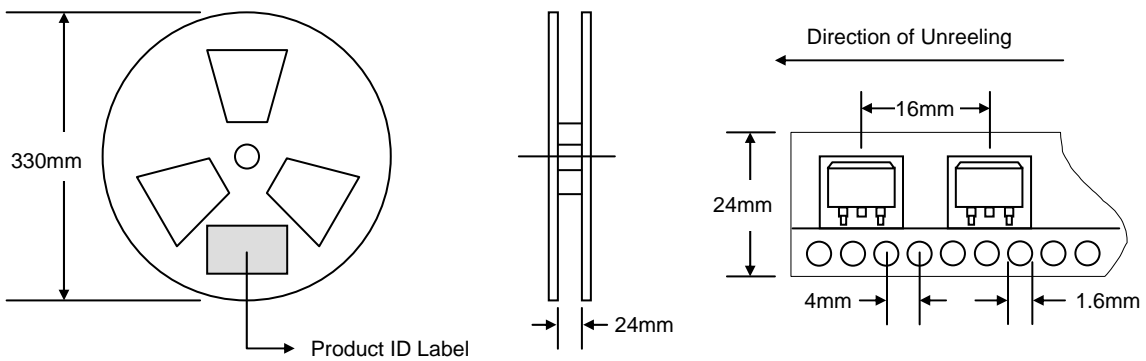

Reel Diameter (mm)	Quantity (PCS)	Inner Box Size L x W x H (mm)	Quantity (PCS)	Carton Size L x W x H (mm)	Quantity (PCS)	Approx. Gross Weight (KG)
330	800	340 x 337 x 45	800	370 x 370 x 420	6,400	15.0