

### Features

- Schottky Barrier Chip
- Guard Ring for Transient and ESD Protection
- Surge Overload Rating to 50A Peak
- Low Power Loss, High Efficiency
- Ideally Suited for Use in High Frequency SMPS, Inverters and As Free Wheeling Diodes

### Mechanical Data

- Case: DO-41, Molded Plastic
- Terminals: Plated Leads Solderable per MIL-STD-202, Method 208
- Polarity: Cathode Band
- Weight: 0.35 grams (approx.)
- Mounting Position: Any
- Marking: Type Number
- **Lead Free: For RoHS / Lead Free Version**

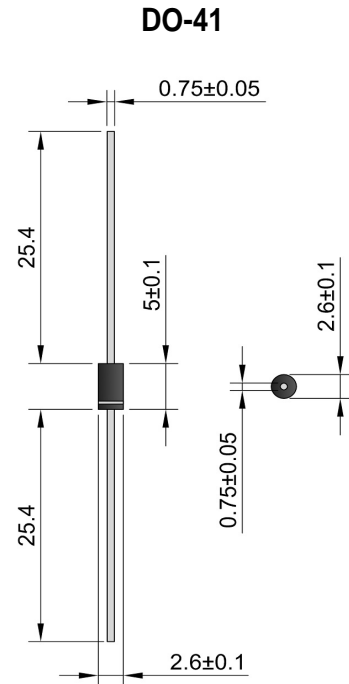

### Maximum Ratings and Electrical Characteristics @T<sub>A</sub>=25°C unless otherwise specified

Single Phase, half wave, 60Hz, resistive or inductive load.  
For capacitive load, derate current by 20%.

Characteristic	Symbol	SB 220S	SB 230S	SB 240S	SB 250S	SB 260S	SB 280S	SB 2100S	Unit
Peak Repetitive Reverse Voltage	V <sub>RRM</sub>	20	30	40	50	60	80	100	V
Working Peak Reverse Voltage	V <sub>RFM</sub>								
DC Blocking Voltage	V <sub>R</sub>								
RMS Reverse Voltage	V <sub>R(RMS)</sub>	14	21	28	35	42	56	70	V
Average Rectified Output Current (Note 1)	I <sub>O</sub>	2.0							A
Non-Repetitive Peak Forward Surge Current 8.3ms Single Half Sine-Wave Superimposed on Rated Load (JEDEC Method)	I <sub>FSM</sub>	50							A
Forward Voltage @ I <sub>F</sub> = 2.0A	V <sub>FM</sub>	0.50		0.70		0.85		V	
Peak Reverse Current @ T <sub>J</sub> = 25°C At Rated DC Blocking Voltage @ T <sub>J</sub> = 100°C	I <sub>RM</sub>	0.5 10							mA
Typical Junction Capacitance (Note 2)	C <sub>J</sub>	150					100		pF
Thermal Resistance, Junction to Ambient (Note 3)	R <sub>JA</sub>	50							°C/W
Thermal Resistance, Junction to Lead (Note 3)	R <sub>JL</sub>	15							
Operating Temperature Range	T <sub>J</sub>	-65 to +125			-65 to +150				°C
Storage Temperature Range	T <sub>STG</sub>	-65 to +150							°C

Note: 1. Leads maintained at ambient temperature at a distance of 9.5mm from the case.  
2. Measured at 1.0 MHz and applied reverse voltage of 4.0V D.C.  
3. Vertical PCB mounting with 12.7mm lead length on 63.5 x 63.5mm copper pad.

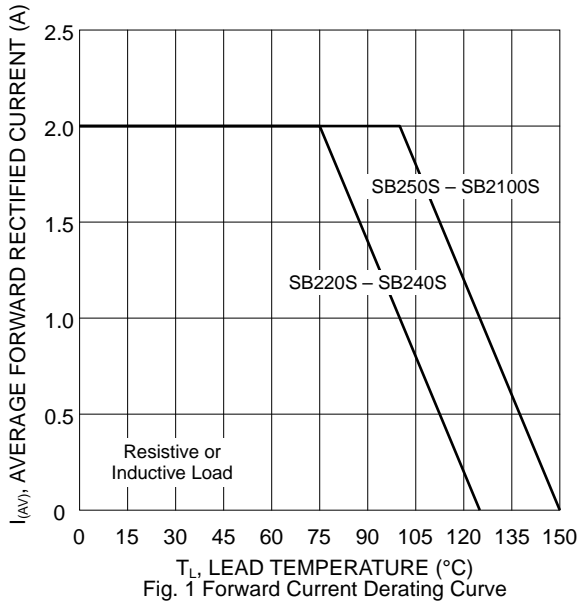

Fig. 1 Forward Current Derating Curve

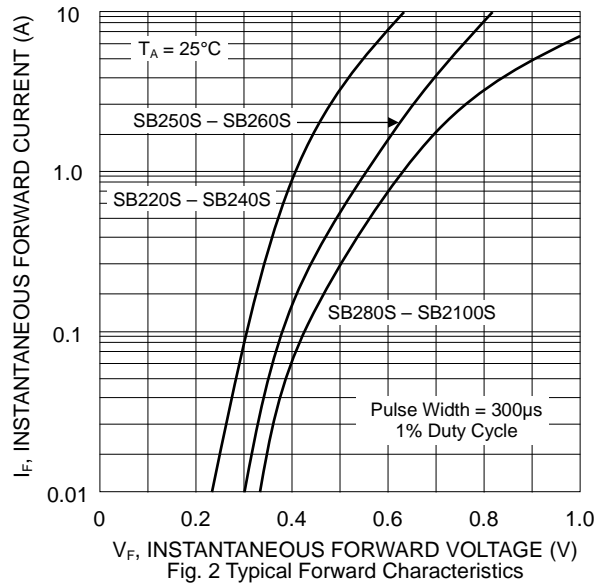

Fig. 2 Typical Forward Characteristics

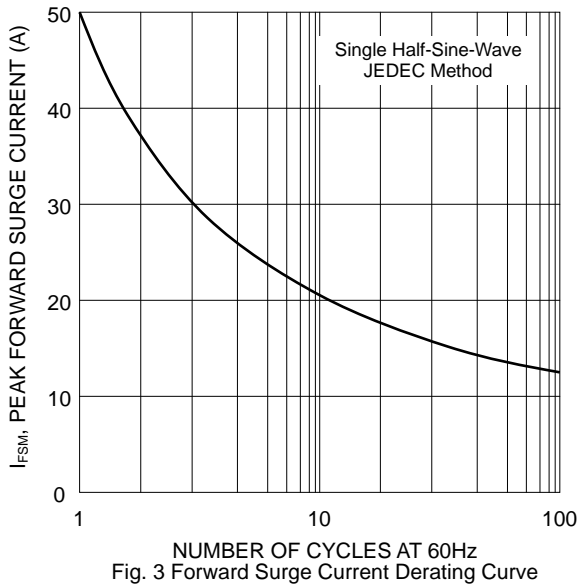

Fig. 3 Forward Surge Current Derating Curve

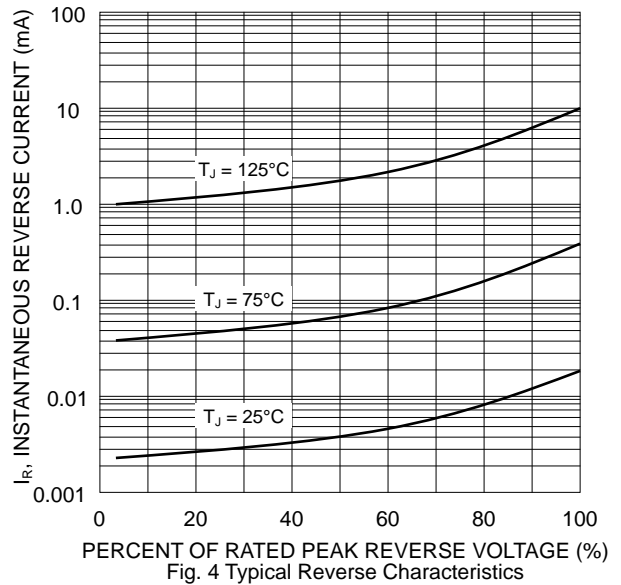

Fig. 4 Typical Reverse Characteristics

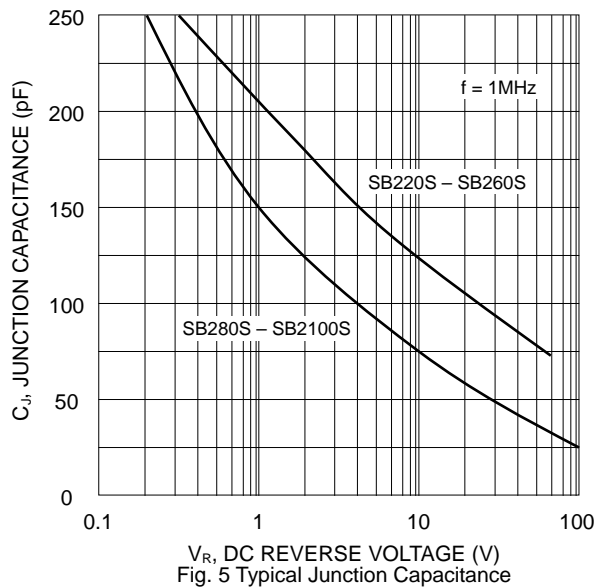
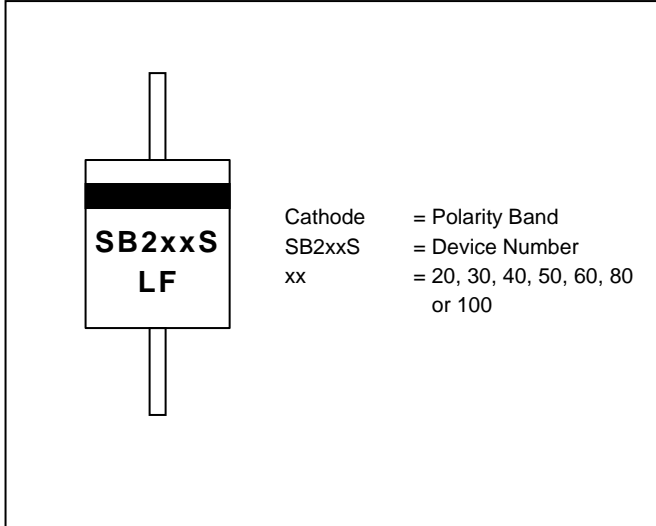
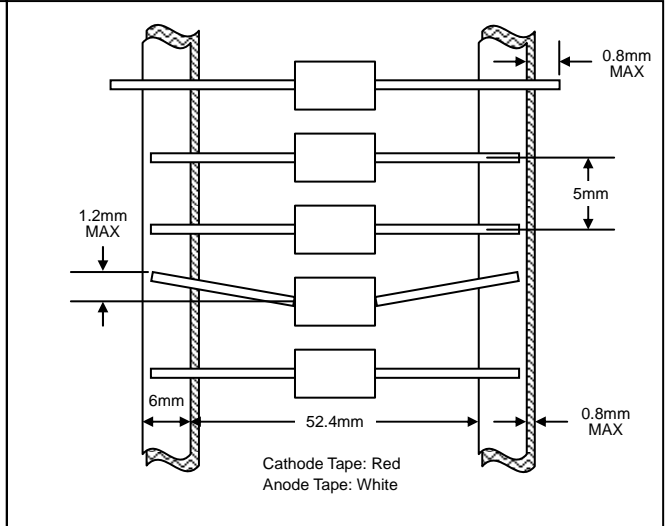

Fig. 5 Typical Junction Capacitance

## MARKING INFORMATION



## TAPING SPECIFICATIONS



## PACKAGING INFORMATION

### TAPE & REEL

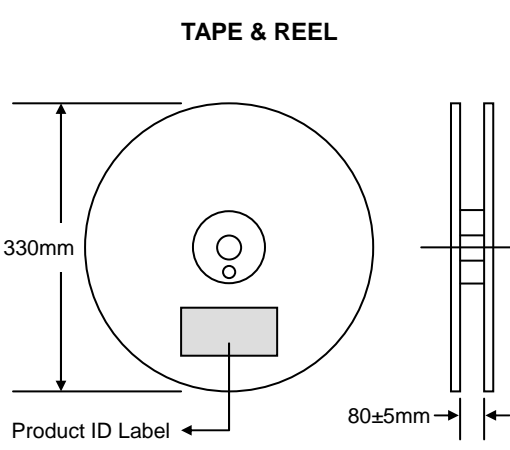

330mm  
 Product ID Label  
 80±5mm

### TAPE & BOX

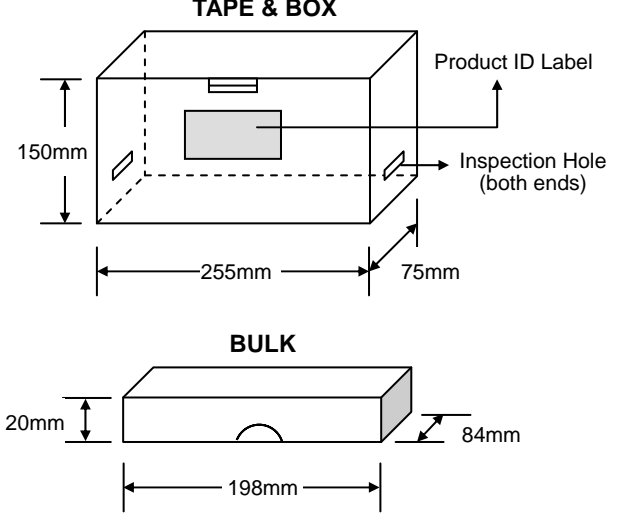

150mm  
 255mm  
 75mm  
 Product ID Label  
 Inspection Hole (both ends)

### BULK

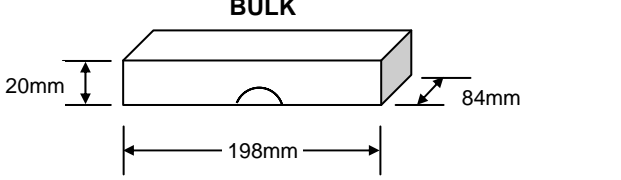

20mm  
 198mm  
 84mm

Packaging	Reel Diameter / Box Size (mm)	Quantity (PCS)	Carton Size (mm)	Quantity (PCS)	Approx. Gross Weight (KG)
<b>TAPE &amp; REEL</b>	330	5,000	370 x 370 x 420	25,000	13.0
<b>TAPE &amp; BOX</b>	255 x 75 x 150	5,000	400 x 273 x 415	50,000	21.0
<b>BULK</b>	198 x 84 x 20	1,000	459 x 214 x 256	50,000	19.5