

### Features

- Schottky Barrier Chip
- Guard Ring for Transient and ESD Protection
- Surge Overload Rating to 180A Peak
- Low Power Loss, High Efficiency
- Ideally Suited for Use in High Frequency SMPS, Inverters and As Free Wheeling Diodes

### Mechanical Data

- Case: DO-201AD, Molded Plastic
- Terminals: Plated Leads Solderable per MIL-STD-202, Method 208
- Polarity: Cathode Band
- Weight: 1.2 grams (approx.)
- Mounting Position: Any
- Marking: Type Number
- **Lead Free: For RoHS / Lead Free Version**

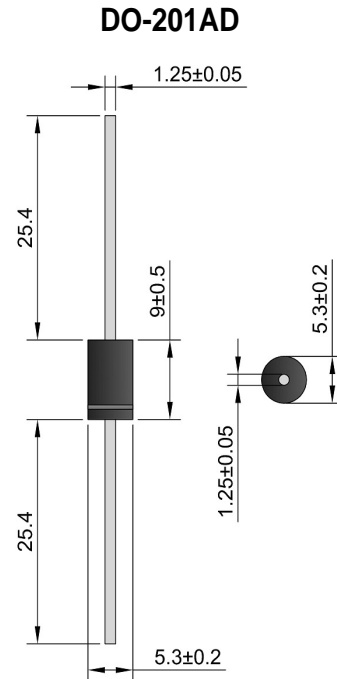

### Maximum Ratings and Electrical Characteristics @T<sub>A</sub>=25°C unless otherwise specified

Single Phase, half wave, 60Hz, resistive or inductive load.  
For capacitive load, derate current by 20%.

Characteristic	Symbol	SD1030	SD1035	SD1040	SD1045	Unit
Peak Repetitive Reverse Voltage	V <sub>RRM</sub>	30	35	40	45	V
Working Peak Reverse Voltage	V <sub>RWM</sub>					
DC Blocking Voltage	V <sub>R</sub>					
RMS Reverse Voltage	V <sub>R(RMS)</sub>	21	25	28	32	V
Average Rectified Output Current @T <sub>L</sub> = 100°C (Note 1)	I <sub>O</sub>	10				A
Non-Repetitive Peak Forward Surge Current 8.3ms Single Half Sine-Wave Superimposed on Rated Load (JEDEC Method)	I <sub>FSM</sub>	180				A
Forward Voltage @I <sub>F</sub> = 10A	V <sub>FM</sub>	0.55				V
Peak Reverse Current @T <sub>J</sub> = 25°C	I <sub>RM</sub>	0.45				mA
At Rated DC Blocking Voltage @T <sub>J</sub> = 100°C		18				
Thermal Resistance, Junction to Ambient (Note 2)	R <sub>JA</sub>	54				°C/W
Thermal Resistance, Junction to Lead (Note 2)	R <sub>JL</sub>	8.0				
Operating Temperature Range	T <sub>J</sub>	-65 to +150				°C
Storage Temperature Range	T <sub>STG</sub>	-65 to +175				°C

Note: 1. Valid provided that leads are kept at ambient temperature at a distance of 9.5mm from the case.  
2. Mounted on FR-4 PCB with 63.5 x 63.5mm copper pads.

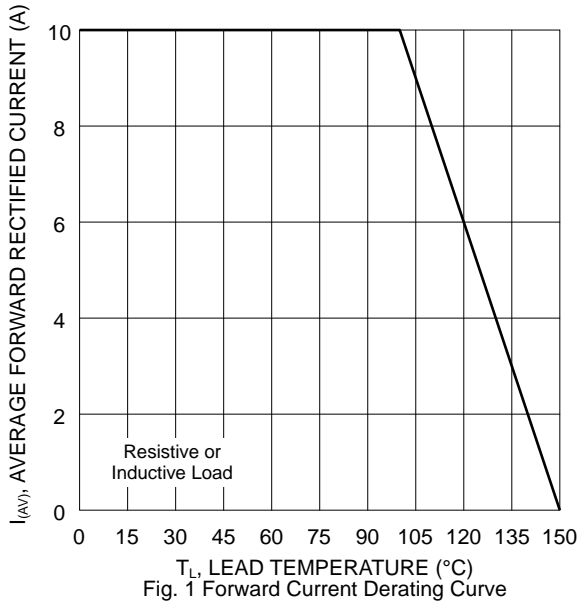

Fig. 1 Forward Current Derating Curve

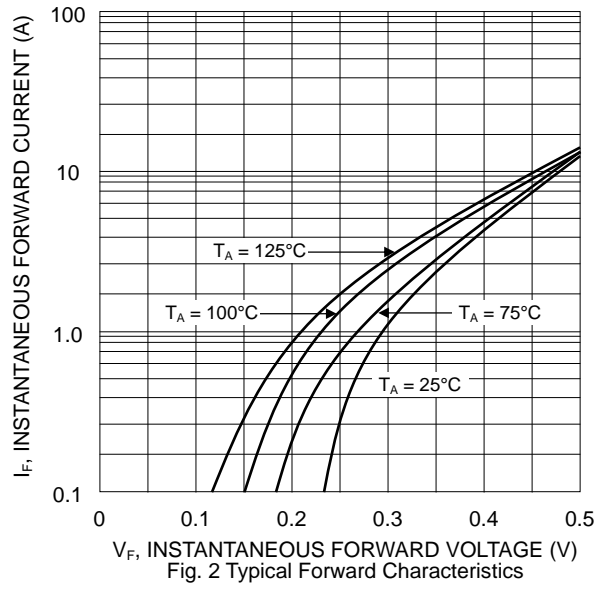

Fig. 2 Typical Forward Characteristics

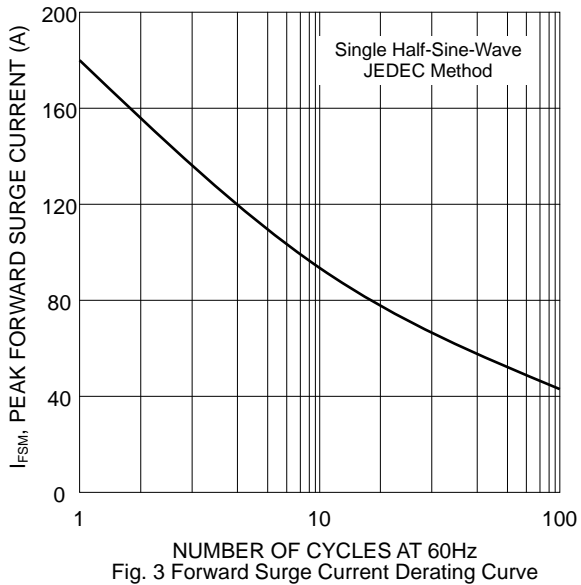

Fig. 3 Forward Surge Current Derating Curve

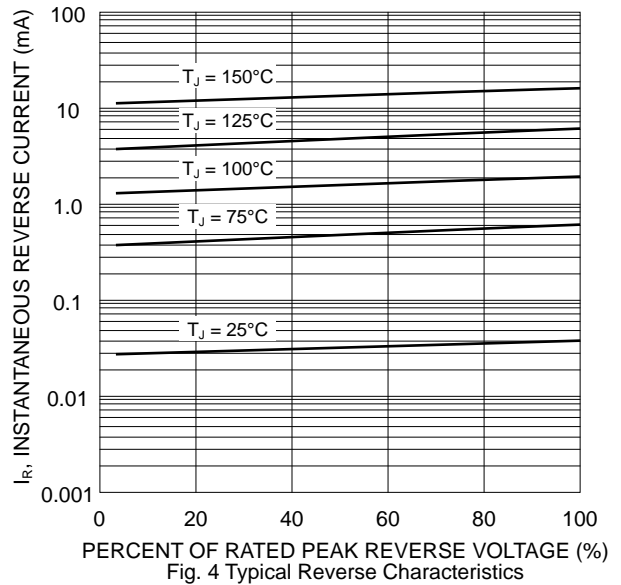

Fig. 4 Typical Reverse Characteristics

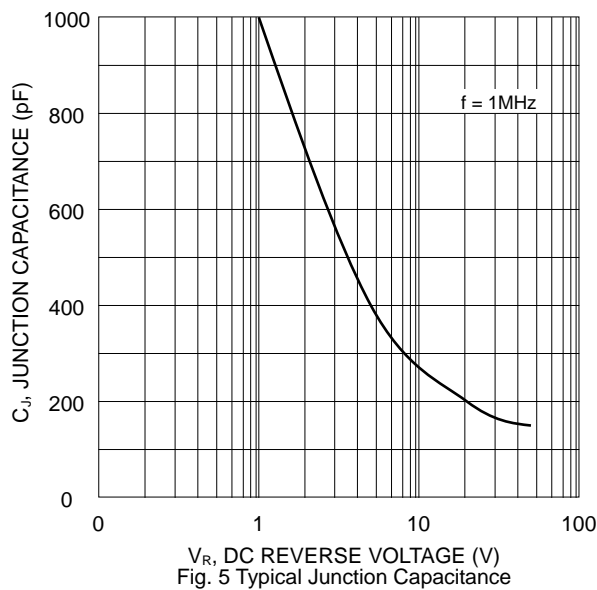
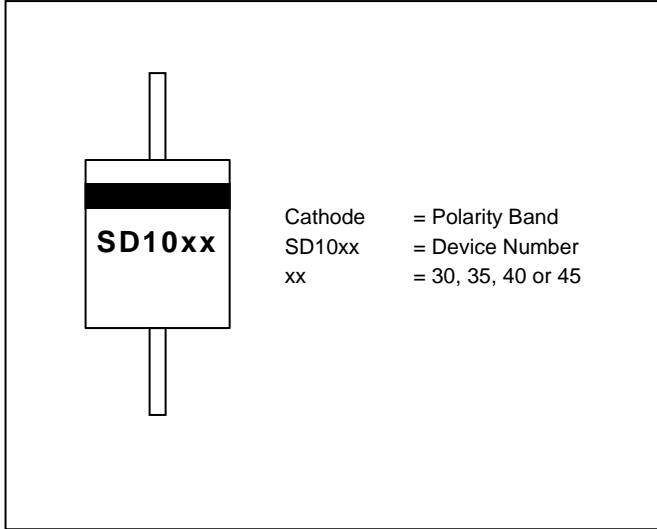
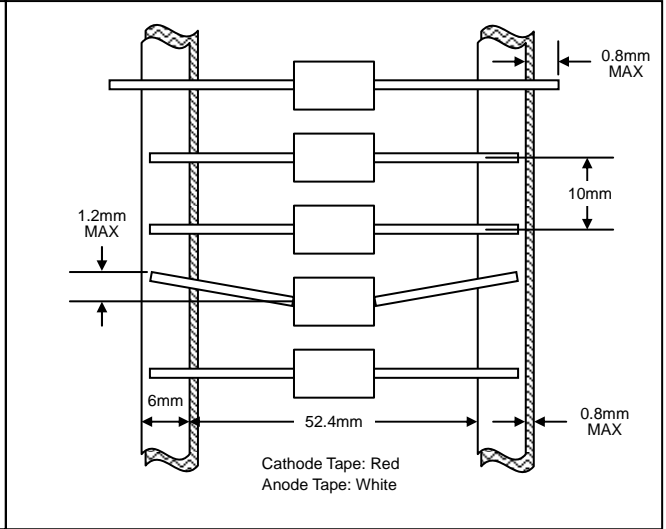

Fig. 5 Typical Junction Capacitance

## MARKING INFORMATION



## TAPING SPECIFICATIONS



## PACKAGING INFORMATION

### TAPE & REEL

330mm  
Product ID Label  
80±5mm

### TAPE & BOX

150mm  
255mm  
75mm  
Product ID Label  
Inspection Hole (both ends)

### BULK

40mm  
200mm  
85mm

Packaging	Reel Diameter / Box Size (mm)	Quantity (PCS)	Carton Size (mm)	Quantity (PCS)	Approx. Gross Weight (KG)
<b>TAPE &amp; REEL</b>	330	1,200	370 x 370 x 420	6,000	10.0
<b>TAPE &amp; BOX</b>	255 x 75 x 150	1,200	400 x 273 x 415	12,000	17.0
<b>BULK</b>	200 x 85 x 40	500	459 x 214 x 256	12,500	16.0